

PROCESS TECHNOLOGIES FOR TOMORROW

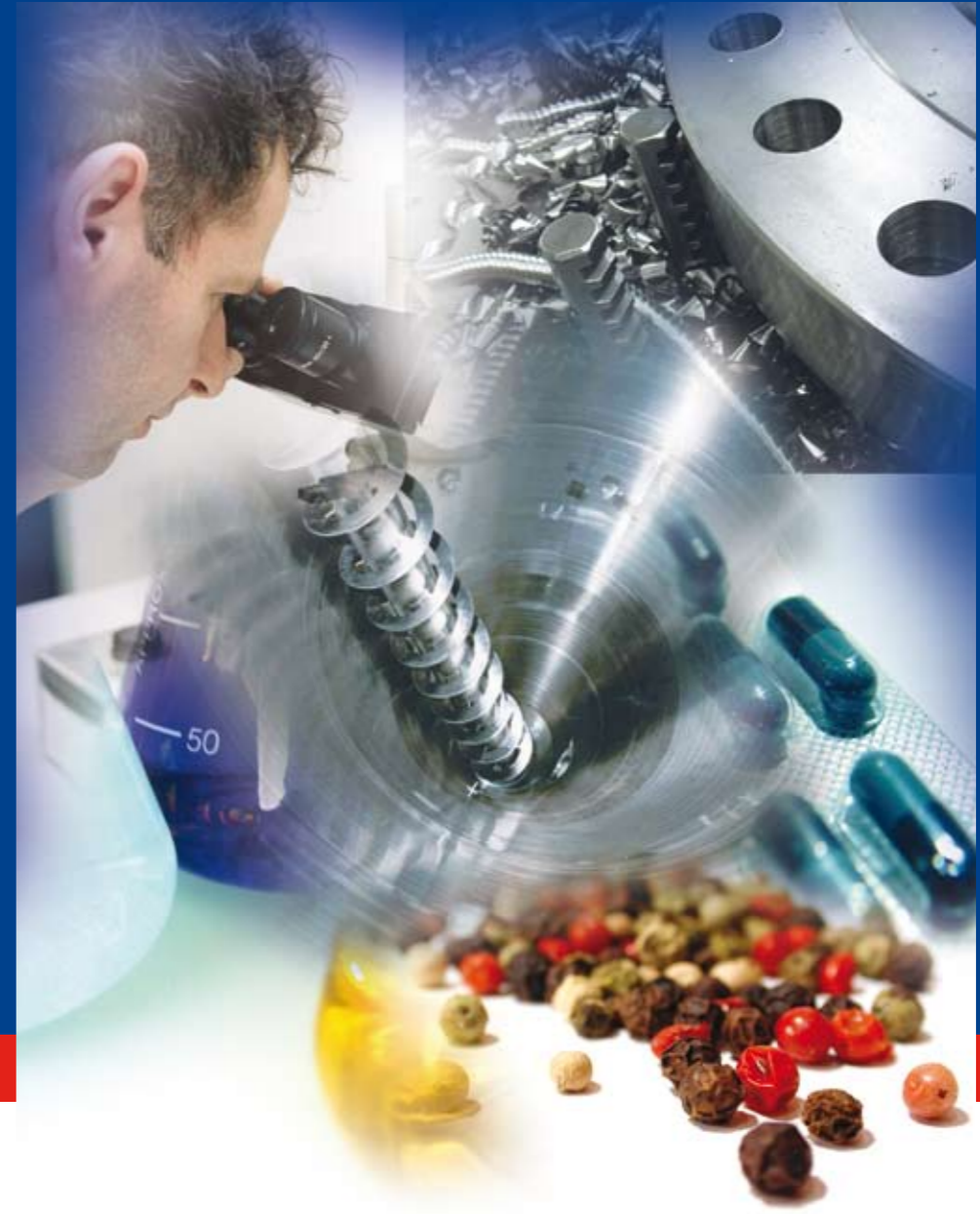

HOSOKAWA MICRON B.V.

Hosokawa Micron B.V. is a member of the Hosokawa Micron Group, responding to global needs through emphasis on materials science and engineering. The Group is an international provider of equipment and technology for powder and particle processing, plastics processing and confectionery products. The Group maintains facilities for research, engineering, manufacturing and service in each of the world's major industrial markets.

© 2006 Hosokawa Micron B.V. Printed in the Netherlands.



HOSOKAWA MICRON B.V.

MIXING DRYING AGGLOMERATION

PROCESS FOR TECHNOLOGIES TOMORROW

The hand that rocks the cradle, rules the world. You may not believe your ears when that statement is made by someone nearly a hundred years old, but you're all ears when that someone is Hosokawa Micron. After all, our years of experience in the field of technology for the powder processing industry allow us to speak our mind on powder processing in the broadest sense of the word. Mixing, drying, agglomeration... in this market, we are true allrounders.

On top of that, we are frontrunners in this market. That is why we speak about Process Technologies for Tomorrow. Why are we frontrunners? Because we're used to it. We can't do anything else, nor do we want to. If we did, we would never have become what we are now: specialist in powder technology. Today, tomorrow and for many years to come.

CONTENTS

TECHNOLOGIES	04
- MIXING	06
- DRYING	10
- AGGLOMERATION	14
- LABORATORY EQUIPMENT	16
- ANCILLARIES	17
SERVICES	18
- ENGINEERING	20
- AFTER SALES SERVICE	22
- TESTING & TOLLING FACILITIES	23
INDUSTRIES	24
- FOOD INDUSTRY	26
- PHARMACEUTICAL INDUSTRY	27
- CHEMICAL INDUSTRY	28
- MINERALS & METALS INDUSTRY	29
CONTACT	30

**FOOD
PHARMACEUTICAL
CHEMICAL
MINERALS & METALS**

TECHNOLOGIES

Mixing, drying, agglomeration... name any process technology connected to powder in any way, and we have the expertise. Our extensive R&D into and broad view on the subject matter explains why we have come up with a large number of well-known and universally recognized developments in powder technology. And why we are still doing just that. It also explains our wide product range and our established reputation in many industries. That reputation is being worked on continuously and keeps growing. Is this all too arrogant? No, the truth of our technological superiority may be told, especially when that truth springs from an organization which -both nationally and internationally- considers engineering, testing and service to be of paramount importance.

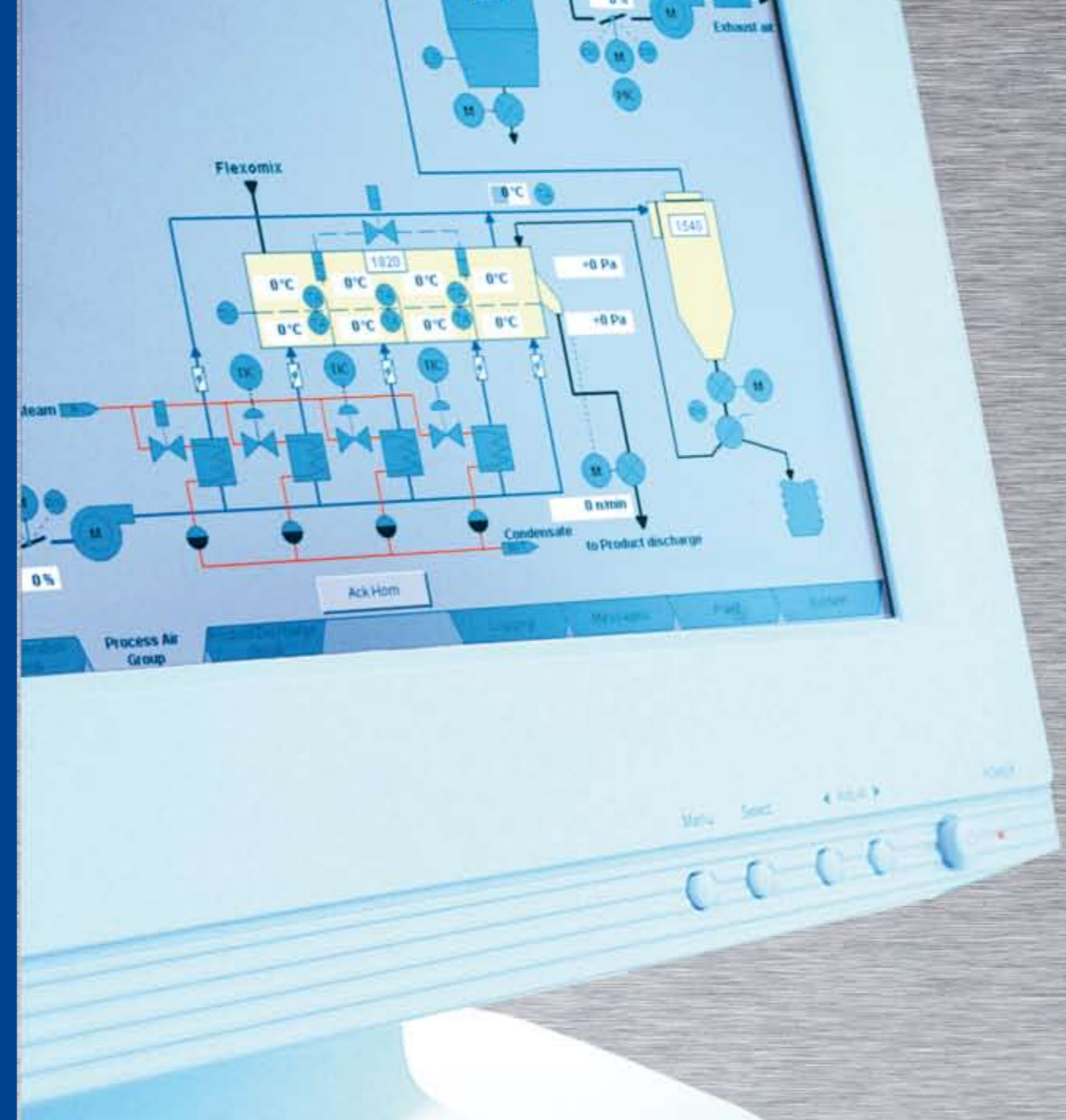

MIXING
DRYING
AGGLOMERATION



MIXING

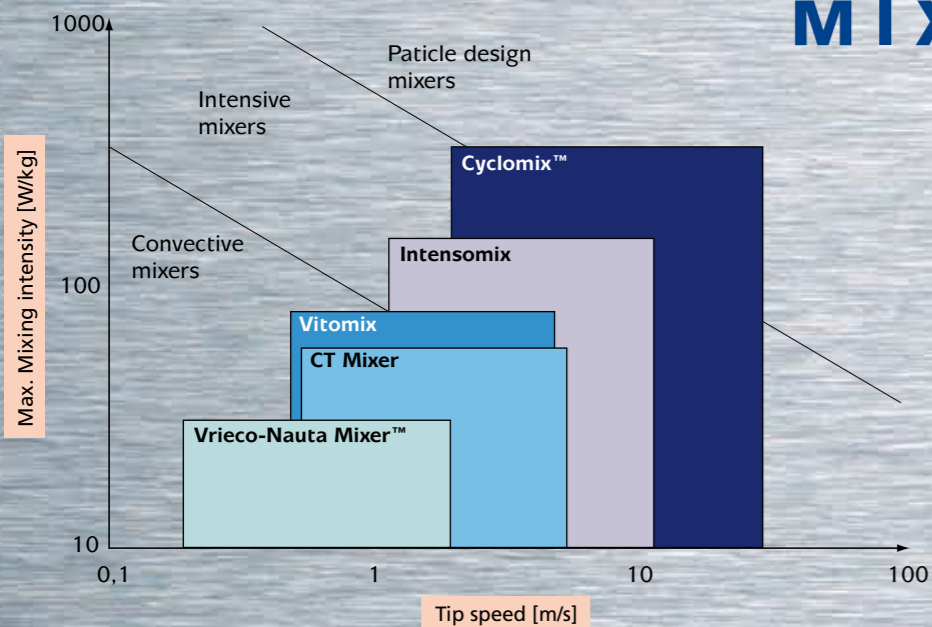

CONICAL SCREW MIXER

The Vrieco-Nauta™ conical mixer is a low intensity mixer specially designed for segregative, free flowing and pasty products. Also applicable for cohesive products when using the intensifier.

Key features:

- High mixing accuracy with a filling ratio from 10 -100%
- Full discharge without segregation and distortion
- Heating, cooling, drying, mixing and moistening
- Available from 5 to 100.000 liters



VERTICAL RIBBON MIXER

The Hosokawa CT-mixer is a conical, vertical ribbon blender especially designed for handling free flowing and cohesive powders.

Key features:

- Quick mixing with a high mixing accuracy and full discharge
- Sanitary design, compatible for CIP and SIP processes
- Perfect heat transfer for heating and cooling processes
- Available from 5 to 6.000 liters

The ideal knowledge mix of markets, products and processing. In other words, the ability to view any mixing problem from every angle. What really counts is that these factors together determine which mixer and which technology offer the best solutions. On that basis, we developed a broad range of mixers and mixing technologies. Our experts are much more than just technicians, with all due respect. We focus our engineering activities on product developments that make a difference. Hence our efforts to facilitate extensive testing, in our own laboratories and in close cooperation with our clients wherever possible. Hence our absolute conviction that with us, you can always count on the mixer that is tailor-made for your markets, products and processes.

RIBBON SCREW MIXER

The Vitomix is a mid shear mixer. Capable of ultra quick cycle times, with up to 8 times more transport volume than conventional screw cone mixers, it uses tip speed from 0,4 m/s till 6,0 m/s.

Key features:

- Fast gentle mixing of powders, pastes and slurries
- Lump free moistening of powders, even without lumpbreakers
- Good temperature control
- Available from 500 to 10.000 liters



RIBBON PADDLE MIXER

The Intensomix is a ribbon paddle mixer designed for an intensive powder transport. It performs well when high shear leads to product deformation and low shear results in inadequate mixing.

Key features:

- Compact design
- Intensive mid shear mixing
- Unique rotor design for maximizing powder transport
- Available from 500 to 25.000 liters

HIGH SHEAR/IMPACT MIXER

The Cyclomix™ is a high shear intensive mixer specially designed for fine cohesive powders, slurry and liquid.

Key features:

- Excellent temperature control
- Intensive mixing, multiple processing like coating, heating and bonding
- Unique intensive mixing capabilities
- Available from 1 to 2.000 liters



MIXING

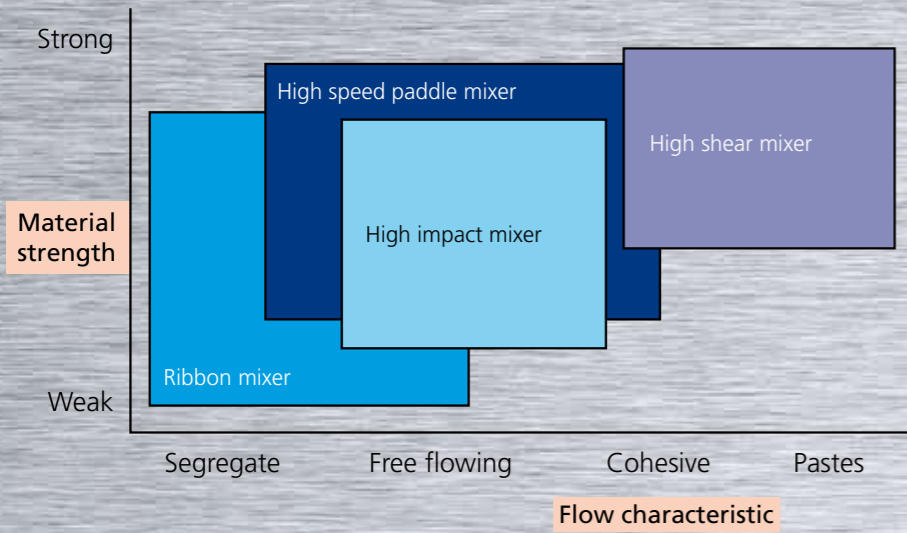

CONTINUOUS MIXING



MODULAR MIXER

The Modulomix is a continuous Modular mixer based on the proven Cyclomix batch mixing technology. It can be used for low, medium or high shear applications and it can be integrated in a PAT environment.

Key features:

- Excellent for mixing active ingredients with carriers and add flow agents (e.g. before pharmaceutical tablet presses)
- Sequential mixing with several modules in series possible
- Low residual material and quick response time
- Capacity from 20kg/hr to 200kg/hr

RIBBON MIXER

The Hosokawa Continuous Ribbon Mixer HMC series is developed for gentle continuous mixing of segregative and free flowing powders.

Key features:

- Compact design with easy access
- Flexible operation with adjustable residence time
- Process flexibility including, heating, cooling and moistening
- Capacities from 0,1 m³/hr to 100 m³/hr



HIGH IMPACT MIXER

The Schugi Flexomix™ is a high intensity continuous mixer, developed to achieve a perfect mixing of free flowing and cohesive powders with liquids.

Key features:

- High mixing accuracy
- Compact and self cleaning design
- Famous for powder-liquid mixing and agglomeration
- Capacities from 50 kg/hr to 40 t/hr

HIGH SHEAR MIXER

The Extrud-O-Mix™ is a low to medium pressure kneader that generates uniform pastes or extrudates. It will accept plastic masses or generate its own.

Key features:

- Intensive mixing of viscous materials or solids with liquids
- Compact design with easy access
- Mixing and kneading in one step
- Capacities from 100 l/hr to 10 m³/hr

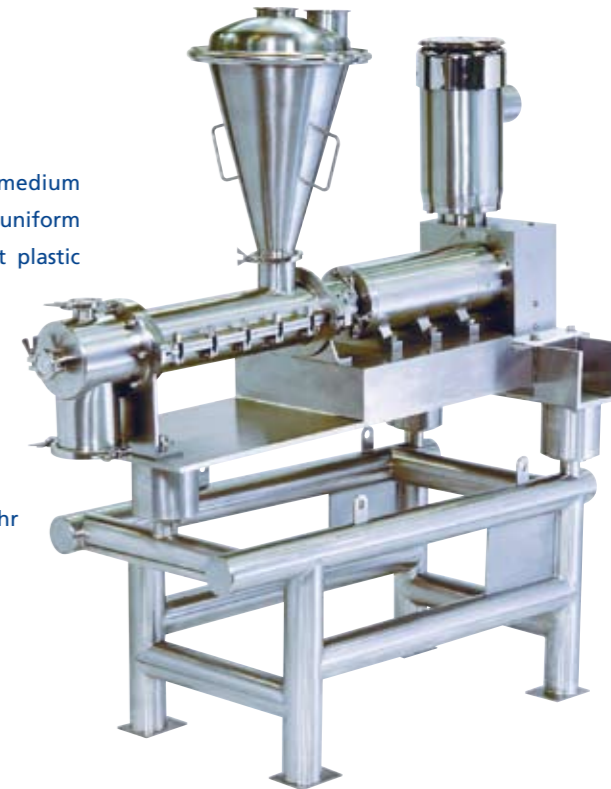

HIGH SPEED PADDLE MIXER

The Turbulizer is a high speed continuous paddle mixer developed for fine and cohesive powder applications.

Key features:

- Flexible operation with mixing energy adjustment
- Perfect temperature control during mixing
- Excellent for coating, heating up and moistening
- Capacities from 100 kg/hr to 100 t/hr

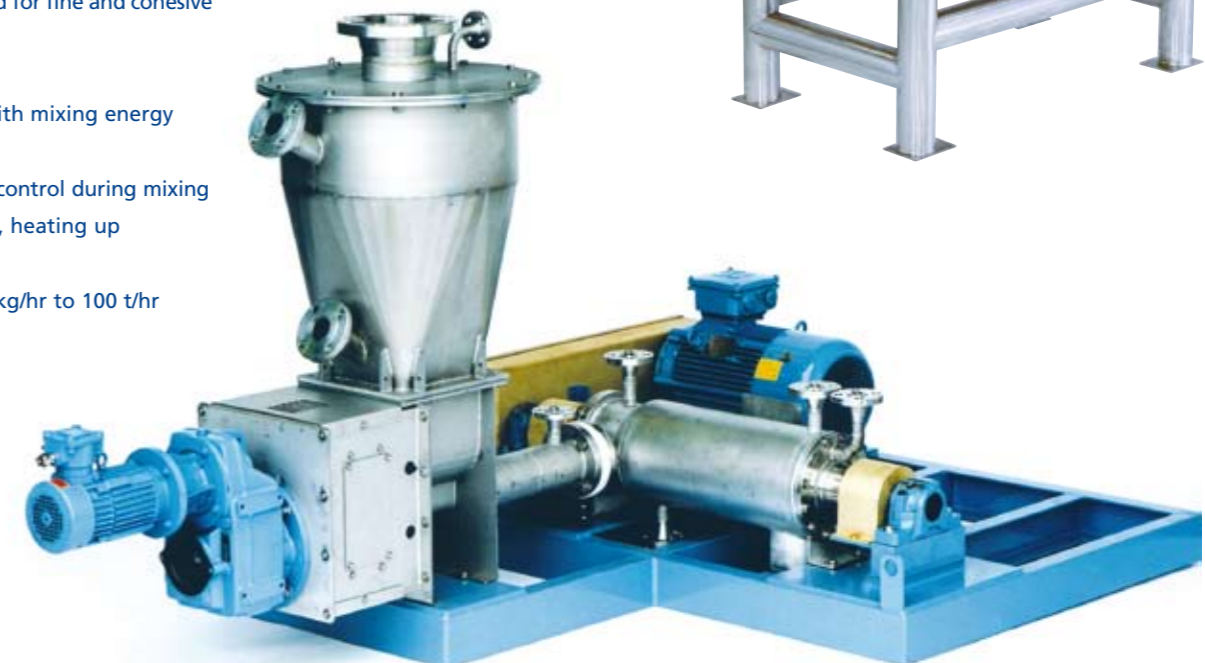

DRYING

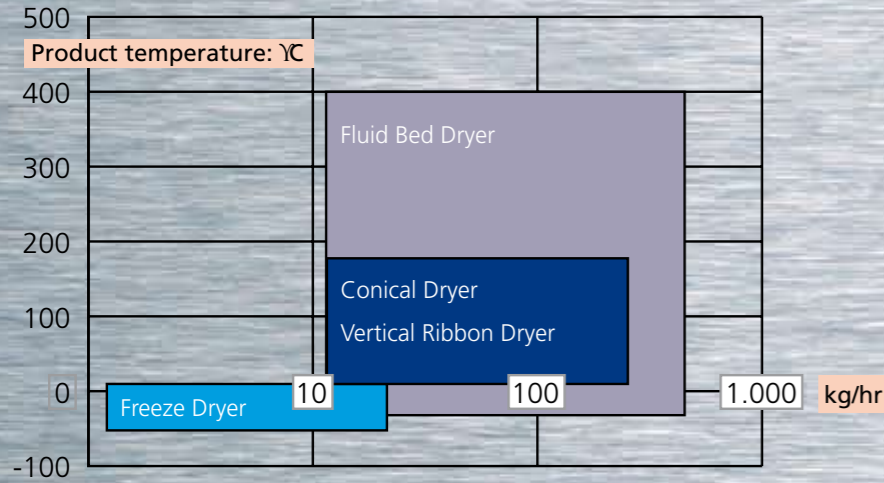

maximum product temperature and the required evaporation capacity

BATCH DRYING



CONICAL SCREW DRYER

The Vrieco-Nauta™ dryer is a well proven design for drying powder, filter cakes, paste and viscous slurries, both under atmospheric or vacuum conditions.

Key features:

- Multipurpose dryer to handle various products
- Excellent mixing properties and suitable for highly sensitive products
- Excellent for secondary drying up to ppm level
- Available from 5 to 20.000 liters

Ever more energy efficient, ever higher capacities and ever lower maintenance. That is the road we are travelling in drying technology. On what exactly is this vision based? On over 50 years of experience and the resulting wealth of market knowledge. On the fact that we cradled many innovations in drying technology, and on market references from over a thousand active units.

The basis is process thinking. Just like drying is always part of something larger, our starting point is always the client's product and process, however specific.

An important, if not deciding factor in our success and innovative leadership is our own in-house pilot plant, in which we test all possible drying techniques for and with clients. Not only in laboratory conditions, but also on a pilot and plant scale.



VERTICAL RIBBON DRYER

The Central shaft dryer is specially designed for efficient drying free flowing powders and filter cakes under vacuum conditions.

Key features:

- Excellent for sterilizing in place (SIP) processes
- Simple mechanical construction outside the vessel
- Optimal heat transfer for free flowing products
- Available from 5 to 6.000 liters



FLUID BED DRYER

The Agglomaster is a batch fluidized bed dryer with additional features for a high versatility and flexibility for drying free flowing powders and cakes.

Key features:

- Unique bottom design to fluidize ultra fine particles
- Particle size control with pulse jet technology to produce ultra fines granulated materials
- Available for powder drying and spray drying
- From 1 to 1.000 liters batch size

ACTIVE FREEZE DRYER

The active freeze drying system is a newly developed dynamic process. Fantastic alternative to tray freeze dryers for bulk powder production. It produces a fine non-lumpy and uniform powder, which is directly available from the product collector.

Key features:

- Short cycle times and high quality end-product
- Fine powder in one step without extra manual handling or de-lumping steps
- Suitable to dry Nano materials
- Available from 5 to 1.000 liters

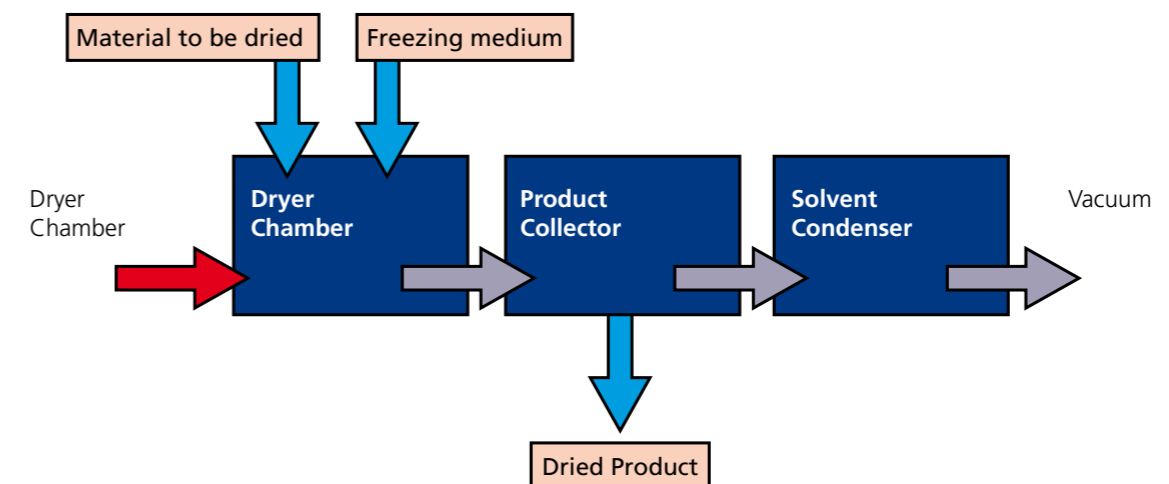

DRYING

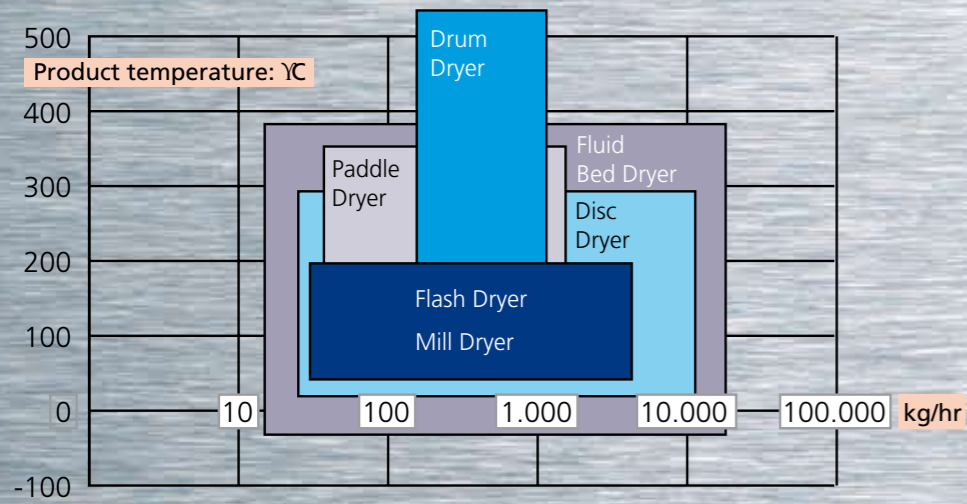

maximum product temperature and the required evaporation capacity

CONTINUOUS DRYING

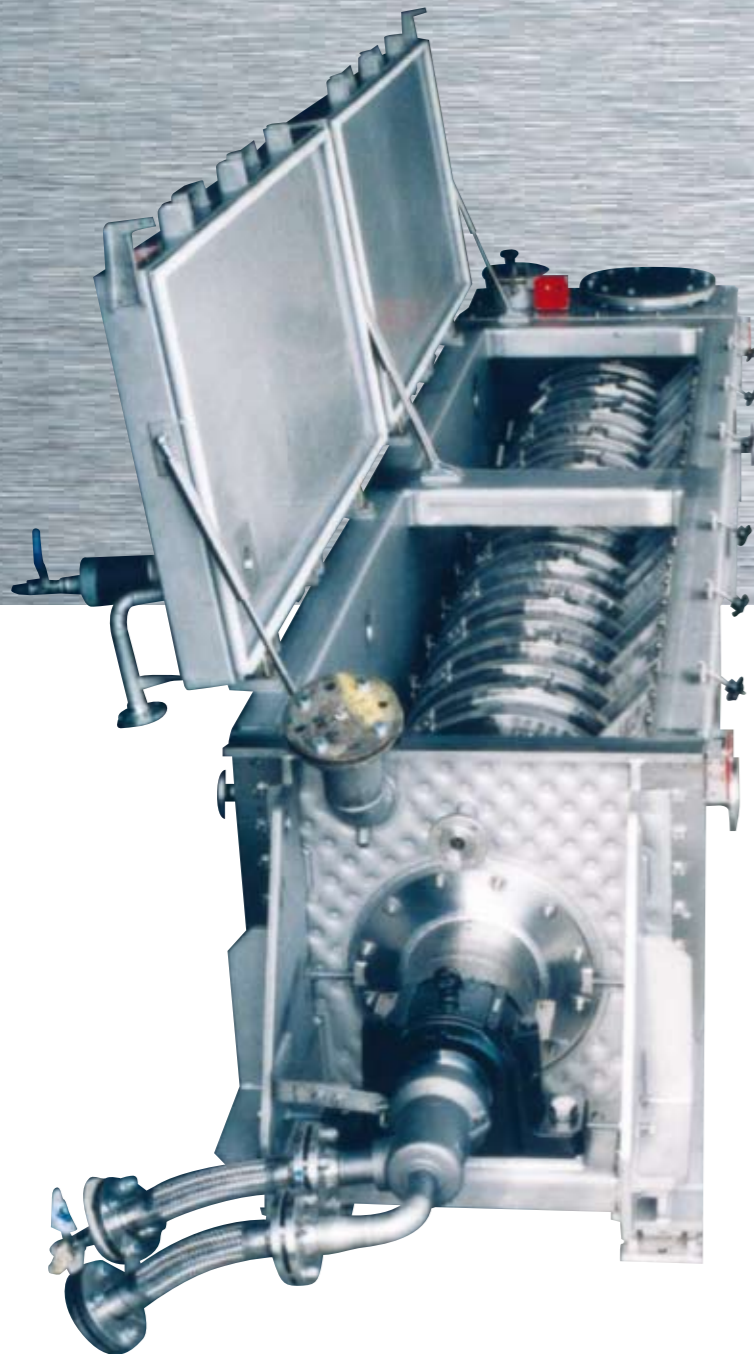

DISC DRYER

The Torusdisc is a low speed horizontal indirect dryer/cooler, suitable for heating and cooling various types of products like filter cakes, powders and granules.

Key features:

- Compact design with a high heat transfer surface up to 400 m²
- Adjustable residence time (15-60 min.)
- Suitable for close-loop operation (e.g. solvent-recovery)
- Evaporation rates up to 35 t/hr

PADDLE DRYER

The Solidaire is a high speed horizontal indirect dryer/cooler. Suitable to heat and dry slurry, filter cakes, paste, powder and granules.

Key features:

- High heat transfer due to high paddle speed
- Nearly plug flow process
- Suitable for close-loop operation (e.g. solvent-recovery)
- Evaporation rates from a few kg/hr up to 10.000 kg/hr



Key features Long Gap mill:

- Up to 750 kW for milling
- Ultra fine grades up 99% < 10 μ
- Suitable for close-loop operation (e.g. solvent-recovery)
- Evaporation rates from 20 to 4.500 kg/hr

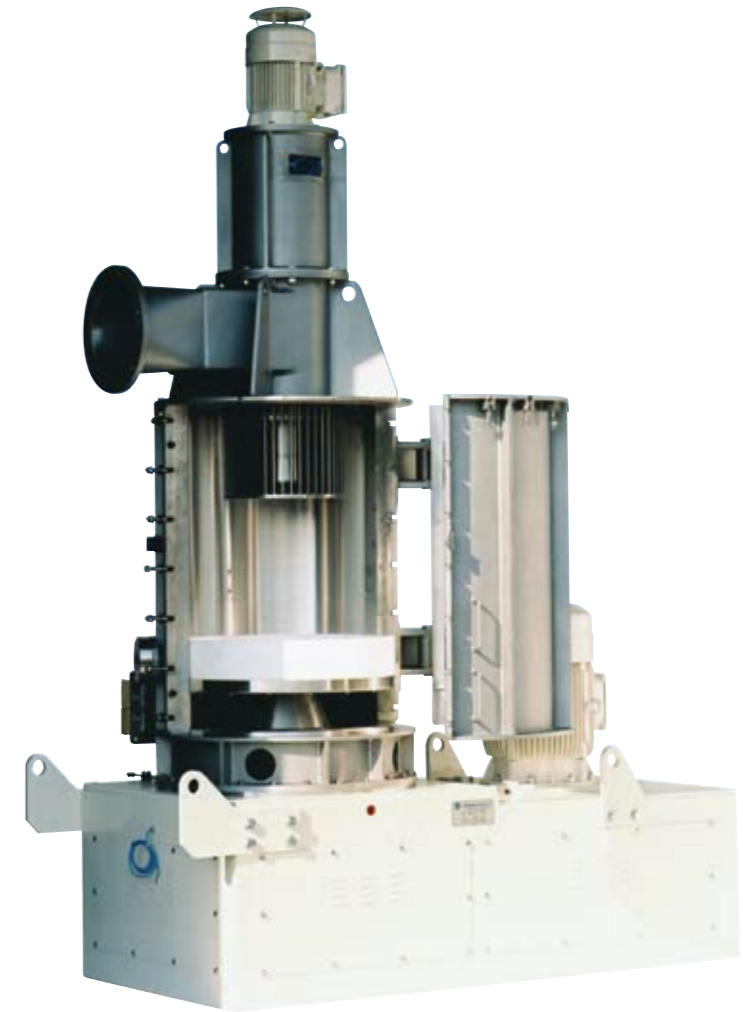

FLASH DRYER

The Micron Dryer, Drymeister and Long Gap mill are flash dryers, capable for drying (or high speed milling & drying) of wet powders, filter cakes, pastes, sticky materials and slurries.

Key features Micron Dryer and Drymeister:

- Produces a uniform and fine product with defined particle size
- High energy efficiency with less than 1 kW/kg of liquid evaporated
- Compact design with space savings up to 50% compared to conventional flash dryers
- Evaporation rates from 20 up to 4.500 kg/hr



AGGLOMERATION

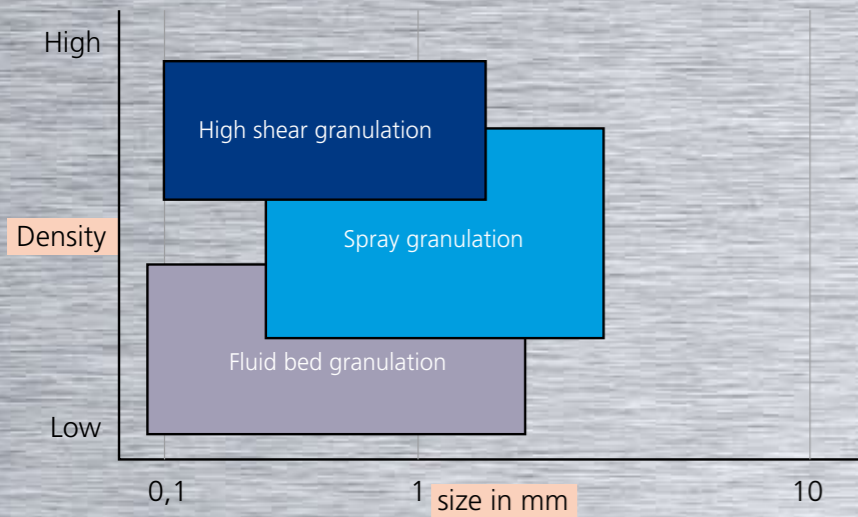

In order to de-dust, to improve flow qualities, to counter segregation, to give powders instant qualities, to optimize product prescription. There are countless possibilities when it comes to applying agglomeration, or the production of granules from powders.

It is therefore only logical that agglomeration technology is widely used in many powder processing industries. The fact that this technology keeps finding new applications in a growing number of markets has a lot to do with our broad experience and expertise. Not only in the field of agglomeration, but also in other well-known powder technologies. It is this diversity that allows us to view agglomeration in a wider context and access the whole process.

BATCH AGGLOMERATION

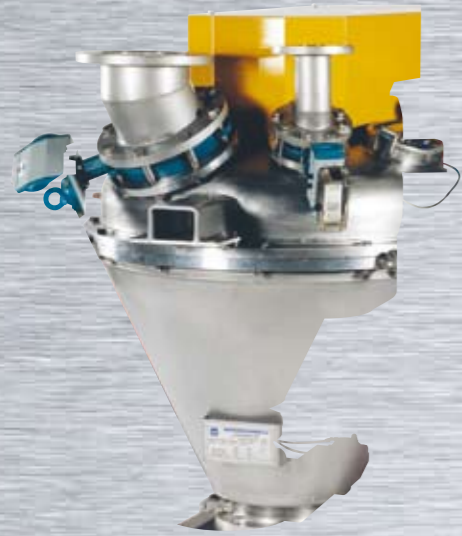

HIGH SHEAR GRANULATION

The Cyclomix™ combines a high shear intensive mixing process and a well-controlled agglomeration mechanism using both melt and liquid binders. Granules of dense structure from 100 µm up to 2 mm can be produced with medium to high density.

Key features:

- Accurate size control of agglomerates
- Short processing times and excellent temperature control
- Possibility for well defined coating and bonding processes
- Available sizes ranging from 1 to 2.000 liters

FLUID BED / SPRAY GRANULATION

The Agglomaster is a multi purpose batch fluidized bed processor with additional features facilitating high versatility and flexibility. Granules with a porous structure up to 1.2 mm can be produced with low to medium density.

Key features:

- Unique bottom design to fluidize ultra fine particles
- Particle size control with pulse jet technology to produce ultra fine granulated materials
- Available for powder granulation and spray granulation
- From 1 to 1.000 liters batch size

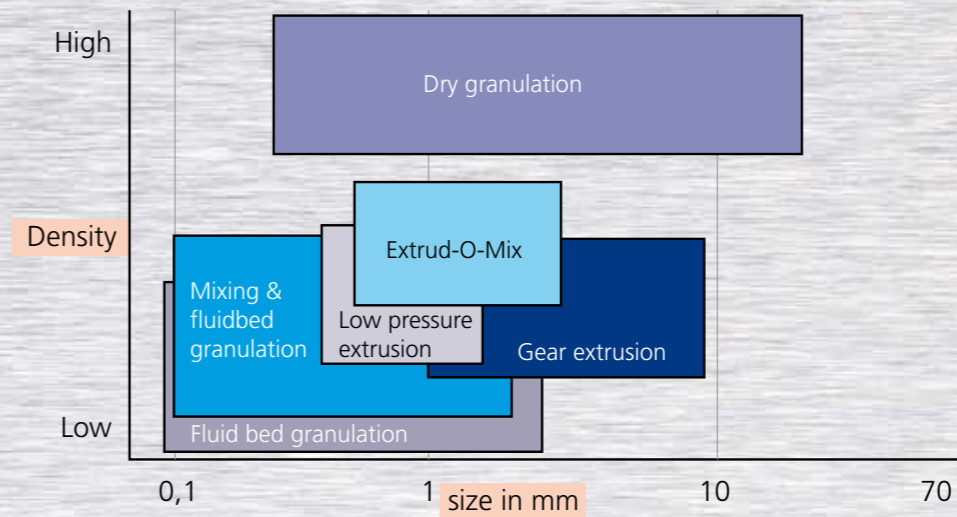

CONTINUOUS AGGLOMERATION



MIXING & FLUID BED GRANULATION

The combination of the Schugi Flexomix™ agglomerator and the Schugi Fluidized Bed Dryer is a perfect concept for agglomeration purposes. Granules with a porous structure from 0.1 to 1.2 mm and with a D50 between 300 and 700 µm can be produced with a low to medium density.

Key features:

- Vertical mixer / agglomerator with self cleaning mixing chamber
- Multiple simultaneous liquid addition possible
- Separate operating units for agglomeration and drying/cooling
- High throughput for the size from 50 kg/hr to 40.000 kg/hr

MEDIUM PRESSURE EXTRUSION

The Extrud-O-Mix™ is a horizontal mixer/kneader, suitable to achieve a highly homogeneous powder-liquid mixture in a continuous process. Extrudates from 1 to 10 mm can be produced with high density.

Key features:

- Mixing and extrusion in one machine
- Compact design including heating/cooling jacket
- Excellent mixing performance
- Capacity from 50 kg/hr up to 2.000 kg/hr

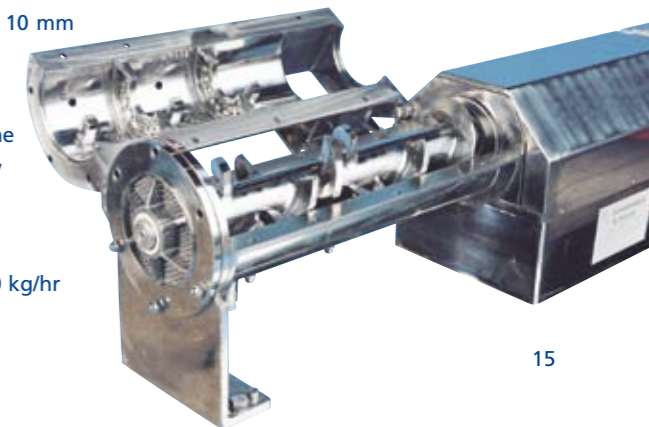

LABORATORY EQUIPMENT

From pilot plant to industrial scale, we cover the whole range. We love to show what we are capable of in the field of testing and trying on a small scale. And like no other, we can apply the results to the bigger picture and the real thing. Consider our laboratory work as an extra certainty: for ourselves, but naturally for our customers as well. Because in this world too, seeing is believing. Moreover, we also sell laboratory equipment, in order to enable our customers to achieve the best possible characterization of their powders. That way there won't be any surprises in subsequent processing stages.



5L CONICAL SCREW VACUUM DRYER



FLASH DRYER MDV-O



1L HIGH SHEAR-IMPACT MIXER



POWDER CHARACTERISTICS TESTER

ANCILLARIES

When, like us, you are at the pinnacle of powder technology, offering complete solutions, you also have to offer a wide range of ancillaries. Ancillaries of our own manufacture that is, and therefore of superior quality, tailor-made to our customers' requirements. Ancillaries may be called by-products, but that doesn't do justice to their properties. Piece for piece, our ancillaries are feats of technical skill, enabling our customers to fully profit from our main products.



BALL SEGMENT VALVES



DENSIFICATION ROTARY VALVE



CRUSHER



CYBERJET



SAMPLE TAKER

SERVICES

The 24/7 economy, ever shorter delivery times, ever more expensive high-tech and therefore larger investments, cutthroat competition... in all these hectic markets, 'downtime' is absolutely unacceptable.

That is why the market demands more security and peace of mind when it comes to machines, but also when it comes to engineering, research & development, testing and service.

It is good to know therefore that we are frontrunners in all these areas. We can pride ourselves on an elaborate range of machines and a wealth of technology and process knowledge. Add to this our highly competent, very experienced engineering department, our truly unique in-house pilot plant and our responsive and smoothly operating service department, and you know your trust is in the best hands.

ENGINEERING
AFTER SALES
TESTING & TOLLING

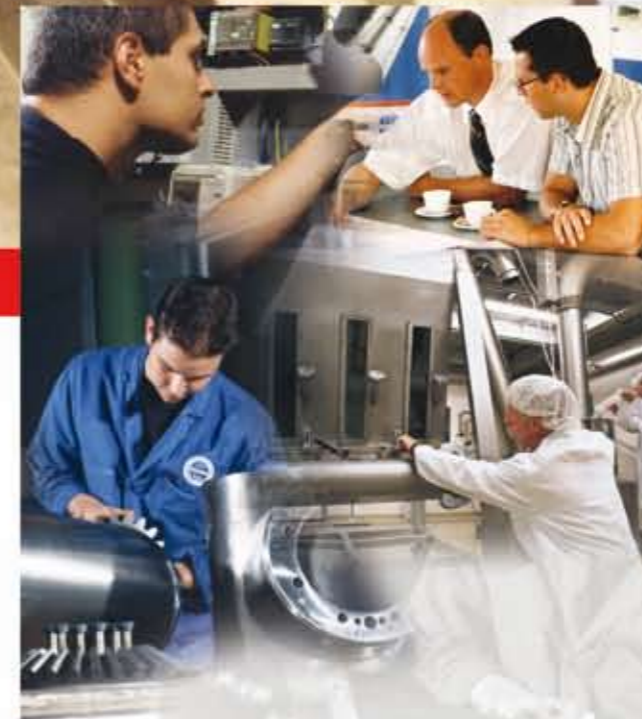

ENGINEERING

Reverse thinking is really what engineering is all about. From the machine back to the process, from the process back to the product, all this is carried out in close cooperation with the client. For if daily practice has proven anything, it is that joining forces (the client knows his product, we have a wealth of knowledge of machines and processes) leads to the best solutions. These in turn lead to the best and most cost-effective production methods.

About best production methods... our ability to research any production process from start to finish in our own in-house facilities is naturally an important advantage to our clients. Our broad technical expertise in mixing, drying, agglomeration and containment is an added bonus, to say the least.

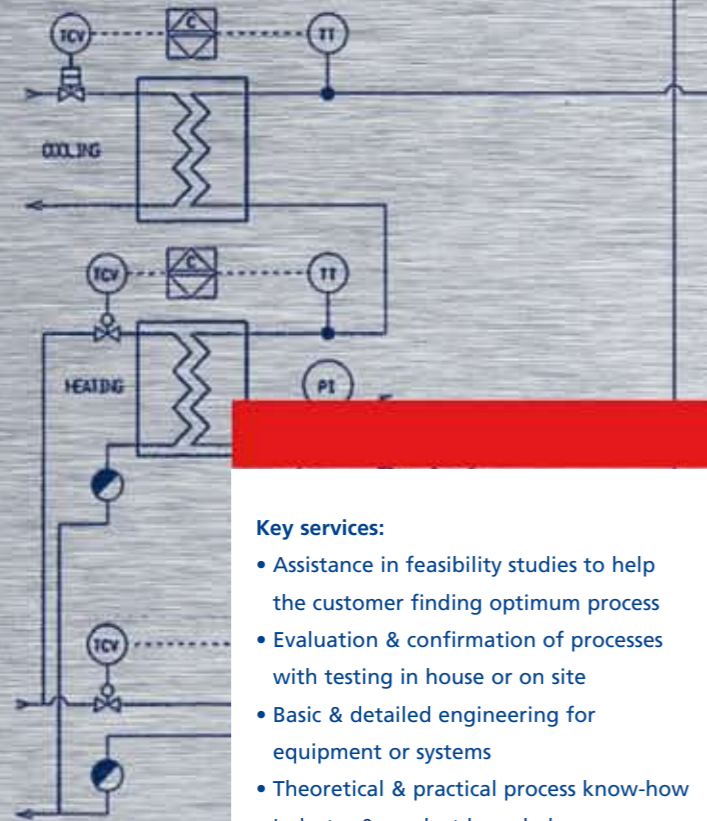

Key services:

- Assistance in feasibility studies to help the customer finding optimum process
- Evaluation & confirmation of processes with testing in house or on site
- Basic & detailed engineering for equipment or systems
- Theoretical & practical process know-how
- Industry & product knowledge
- Project management including validation services, commissioning and start up
- Know-how & experience to comply with all international standards & guidelines like ATEX
- Quality control

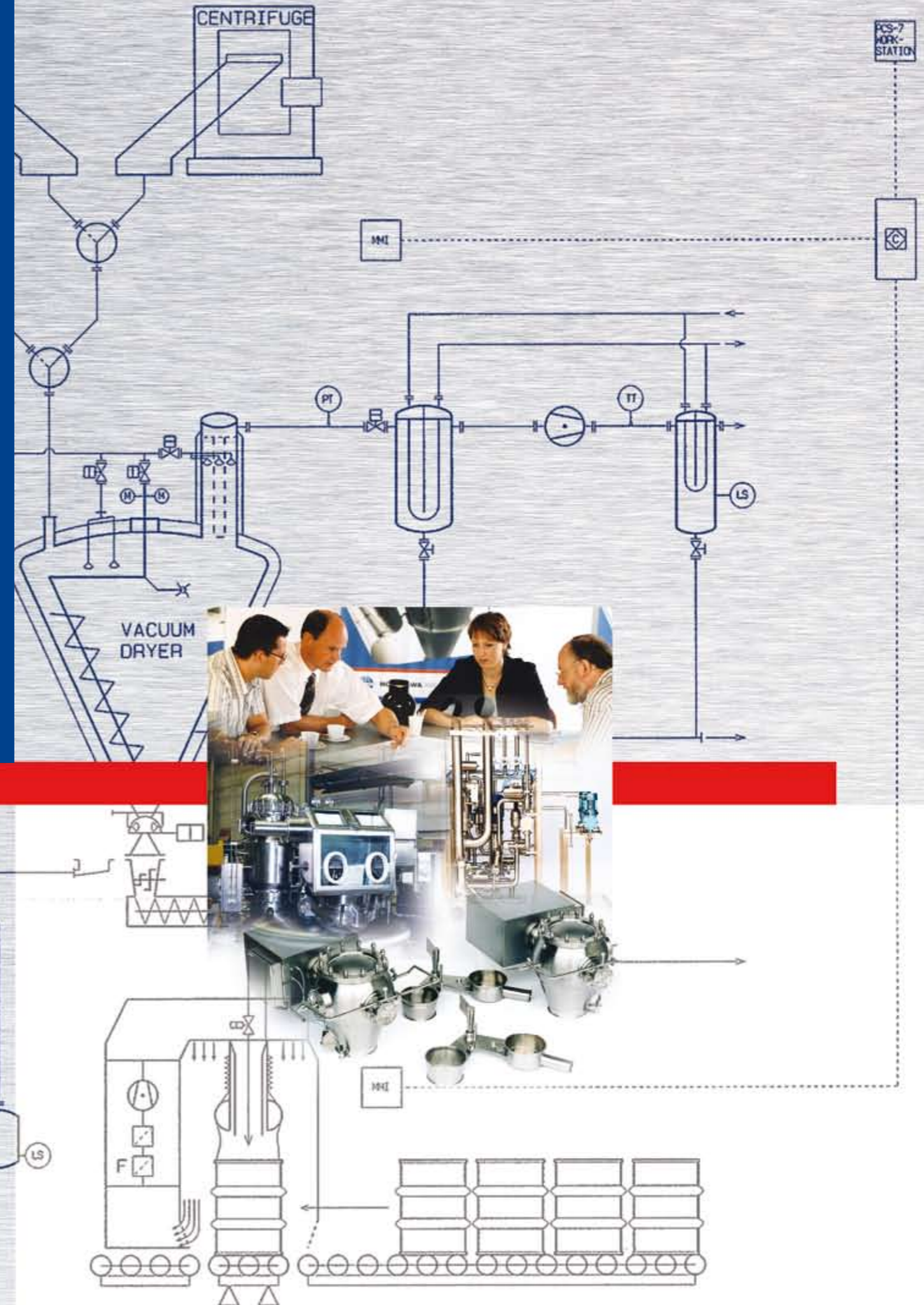
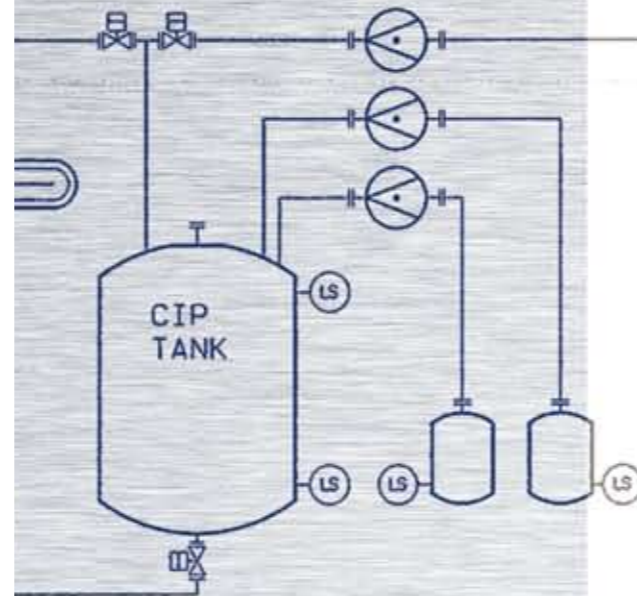

AFTER SERVICE



SALES

Quality, reliability and predictability. Completely eliminating the risk of breakdowns, or at least keeping them to an absolute minimum. Clients want more, demand more than 'just' a top quality product. This is what they get from us, in the shape of a smoothly operating after sales service, which meets their growing expectations in every regard. Long-term contracts in cast-iron agreements are the norm, rather than the exception. These contracts and agreements are often very specific and tailor-made for any client, whether it is about 24 hour on site-service or the complete outsourcing of the entire stock control.

Speaking of tailor-made... apart from contracts and agreements, it goes without saying that you can rely on our service mechanics always being well trained and up-to-date in every discipline, whether it be mechanical and electrical, or process and control technology.

On site services

- Preventive maintenance
- Inspection and trouble shooting
- Repair & service
- Process support and optimization
- Modifications and upgrading to the latest technology
- Internal transport, re-location and erection
- Operator training either on site or in Doetinchem
- Commissioning
- Certification and validation
- Reconditioning of used machines

TESTING & TOLLING FACILITIES



If the behaviour of powders could be summarised in a set of rules and laws, in other words if it could be predicted, then testing would be unnecessary. Success would be guaranteed, with any treatment or processing of any product whatsoever. Of course reality is somewhat different, if only because developments in nanotechnology are continuously leading to new high-tech powder technologies.

This explains why testing is our natural resort and why we have our own well-equipped and ultramodern testing facilities. Here we can test and develop both existing and new machines. We often work on technology in partnership with clients, as customer feedback is critical. We also act as contractors in producing smaller batches for clients, to ensure maximum quality and repeatability for them.

Testing

We offer a unique infrastructure for testing powder processes like:

- Batch mixing: from 1 up to 3.500 liters
- Continuous mixing: from 10 kg/hr up to 1.000 kg/hr
- Batch drying: from 2 up to 3.500 liters
- Continuous drying: from 20 kg/hr up to 80 kg/hr
- Batch agglomeration: from 1 up to 250 liters
- Continuous agglomeration: from 50 kg/hr up to 500 kg/hr
- Crushing, sieving and densification
- Dry and wet Cleaning In Place

Rental Equipment

Although all equipment is installed in our test station, for customer convenience, rental units of some technologies are also available for installation at the customers site.

Toll processing

Since a couple of years, in Doetinchem, we installed contract processing facilities to help customers to go from research phase to production phase. Contract processing is mainly offered to clients for:

- Processing materials before customers run on their own installation
- Market test
- Customer process development

INDUSTRIES

Our very diverse approach to processing technology, our many years of multi-disciplined experience, our place in a well established global organization, and of course our focus on solutions in customer service: all this has contributed to our sound reputation across a wide industry base.

Especially in the food industry, the pharmaceutical industry, the chemical industry and the minerals & metals industry, we are held in high regard as a team which knows the ropes in each and every one of these sectors. A team moreover, which can pride itself on expertise in a wide variety of processes and applications.

FOOD
PHARMACEUTICAL
CHEMICAL
MINERALS & METALS



FOOD INDUSTRY

APPLICATIONS & PROCESSES

- Batch and continuous mixing of multiple ingredients like dairy products, bakery products, sweeteners, thickening agents
- Batch pasteurization
- Taste masking of food supplements
- Continuous flash mill drying of thickeners
- Steamsterilisation and intensive mixing of spices, herbs and seeds
- Heat treatment or modification of flours and starches
- Continuous agglomeration of instant products
- Batch agglomeration and spray granulation of flavours and sweeteners
- Production of tableting mass
- Drying of food production residues
- Surface modification of sugar based product
- Alkalisiation of cacao nibs
- Drying and sterilizing of fish meal

SOME TYPICAL PRODUCTS HANDLED

- Potato starch, wheat starch and tapioca starch, flours, alginates, CMC, bakery mix and cereals
- Gelatines, carrageenan, agar agar, pectin, gum and xanthane
- Lactose, egg powder, milk powder and lactitol
- Flavours, fragrances, spices and herbs
- Silk sugar, sorbitol, dextrine, cocoa mixtures and nougat
- Food preservatives
- Vitamins and mineral premixes for animal food and milk replacer
- Carrot, fish, soya, okara

OUR SPECIFIC SERVICES

- Application and process advice
- Engineering, designing and manufacturing of turn-key installations
- To meet today's hygiene and sanitary standards, all our equipment manufactured in full compliance with international standards and guidelines like FDA, EHEDG, 3A.
- Contract production services on mixing, drying, coating and agglomeration in house or with third parties
- Carrying out trials, production of samples of a few kg to a few tonnes for market and client surveys

PHARMA INDUSTRY

APPLICATIONS & PROCESSES

- Mixing, homogenisation and coating of active ingredients before tablet press of powders, and granulated products
- Coating of ultra fine bulk carrier with liquids and/or nano-active ingredients
- Dispersion of solids into liquids and emulsion
- Vacuum drying of active pharmaceutical ingredients and carriers coming from centrifuges or spray drying
- Wet granulation with fluid bed and high shear technologies
- Containment solutions up to less than $1 \mu\text{g}/\text{m}^3$
- Continuous agglomeration systems for veterinary pharmaceutical products
- Mixing/dispersion line for cosmetics like eye liners and facial products
- Pharmaceutical valves for vacuum & pressure operation

SOME TYPICAL PRODUCT HANDLED

- Bulk pharmaceutical products, granules, tablets suspensions, inhaling and injection drugs
- Active of highly active pharmaceutical ingredients
- Carriers like lactose, starch, CMC
- Sterile and non sterile products
- Primary and secondary pharmaceutical products
- Raw materials to make veterinary products
- Vitamins and tooth paste
- enzymes

SPECIFIC PHARMACEUTICAL SERVICES

- Experience & expertise in making and executing validation documentation and protocols: DQ (QPP, FS, FAT,.), IQ (e.g. stationary SAT), OQ (e.g. dynamic SAT) and assistance for PQ
- Compliance with the latest standards like GAMP4 and 21 CFR 11
- Dedicated project management
- Process development with our unique test station from laboratory scale to industrial scale
- Supply of CIP or SIP solutions; Cleaning In Place testing facilities
- Supply of single units to turnkey systems for mixing, drying, and agglomeration technologies

CHEMICAL INDUSTRY

APPLICATIONS & PROCESSES

- Mixing and addition of additives before and after grinding
- High shear mixing / coating of powders
- High intensity mixing of slurry
- Continuous drying of organic, inorganic pigments
- Mixing and homogenisation of bulk materials in volumes up to 100 m³
- Life hoppers for products with poor flow products
- Mixer / Hopper (Master batch) in front of extruder
- Batch drying of performance plastics, pigments
- Flash drying and milling of cellulose and zinc phosphate
- Solid phase polymerisation of polyester pellets
- Mill- drying of wet grinded slurry down to 1 µm
- Production of wet dispersible granular pesticides
- Drying and mixing for chemically produced toner
- Specialty valves for vacuum & pressure operation

SOME TYPICAL PRODUCTS HANDLED

- Pigment powders and slurries, like titanium dioxide, zinc phosphate
- Plastics (PE / PP / PVS / ABS / HOPE / PET) and plastics additives
- Fungicides, insecticides, herbicides
- Super absorbent polymers
- Technical starch derivatives
- Phosphates
- Catalysts
- Raw materials of rechargeable batteries
- Detergents for powder or tablet form
- Glues, wall plasters, CMC
- Inorganic salts like aluminium hydroxide
- Basic chemicals compounds

OUR SPECIFIC SERVICES

- Application and process advice
- Carrying out trials, production of samples of a few kg to a few tonnes for market and client surveys
- Contract production services on mixing, drying, coating and agglomeration in house or with third parties
- Engineering, designing and manufacturing of turn-key installations

MINERALS & METALS INDUSTRY

APPLICATIONS & PROCESSES

- Mixing of metal or oxide powders and pastes for products like iron, aluminium and bronze
- High accuracy mixing of minerals and metals with additives, pigments or flow agents before sintering, calcinations or compaction
- Coating of minerals and metals with waxes or melt binders to manipulate typical product characteristics
- Wet agglomeration by fluid bed and high shear technologies of iron oxide, and raw materials for rechargeable batteries
- Direct and indirect drying of cakes and slurries like rare earths
- Flash drying, milling and classifying of wet grinded products down to few µm
- Vacuum drying of nuclear waste

SOME TYPICAL PRODUCTS HANDLED

- Minerals, limestone, dolomite, talcum, perlite, silica, graphite, gypsum, cement, sand, phosphate, marble.
- Kaolin, bentonite, carbonates
- Ceramics, quartz, copper oxide, aluminium oxide, magnesium
- Abrasives, SiC, SiO, boron carbide, diamonds, tungsten carbide
- Metals, iron powders, tungsten, cobalt, nickel, lead, aluminium, bronze, molybdenum, copper, chromium, alloys
- Nuclear fuels, uranium oxide / di-oxide, plutonium

OUR SPECIFIC SERVICES

- Application and process advice
- Process simulation to prove product quality and process functionality.
- Contract production services on mixing, drying, coating and agglomeration in house or with third parties
- Developing, design, engineering, manufacture, installation and service from single unit to turn key system.

HOSOKAWA MICRON GROUP WORLDWIDE

Hosokawa is the world's largest provider of processing systems for the field of powder and particle processing. Renowned names such as Alpine, Bepex, Micron, Mikro, Stott, Vitalair and Vrieco-Nauta™ are all included in the Group's range. Regardless of the size, i.e. production-scale systems, pilot systems or laboratory equipment, Hosokawa's products and technologies are used in numerous process stages, for example during mixing, drying, agglomeration, containment, filling, metering, size reduction and classification.

CONTACT

THE NETHERLANDS

Hosokawa Micron BV
Gildenstraat 26
PO Box 98
7000 AB Doetinchem, NL
Phone: +31 (0)314 37 33 33
Fax: +31 (0)314 37 34 56
E-mail: info@hmbv.hosokawa.com
Internet: www.hosokawamicron.nl

TEAM FOOD/PHARMA

Phone: +31 (0)314 37 34 62
Fax: +31 (0)314 37 34 91
E-mail: fp@hmbv.hosokawa.com

TEAM CHEMICALS/MINERALS/METALS

Phone: +31 (0)314 37 34 60
Fax: +31 (0)314 37 35 22
E-mail: cmm@hmbv.hosokawa.com

TEAM SERVICE

Phone: +31 (0)314 37 33 74
+31 (0)314 37 33 75
Fax: +31 (0)314 37 34 31
E-mail: service@hmbv.hosokawa.com

Service Help Desk
After office hours
Phone: +31 (0)314 37 35 05

